



555-540-711  
Issue 1  
1989

# **AT&T System 25**

# **Cordless Telephone**

## User Guide

**©1989 AT&T  
All Rights Reserved  
Printed in USA**

**TO ORDER COPIES OF THIS DOCUMENT REFER TO DOCUMENT  
NUMBER 555-540-711.**

Contact: Your AT&T Sales Representative, or

Call: 800-432-6600, Monday to Friday between 7:30 am  
and 6:00 pm EST.  
In Canada dial 800-255-1242, or

Write: AT&T Customer Information Center  
285 North Franklin Road  
P.O. Box 19901  
Indianapolis, Indiana 46219

Every effort was made to ensure that the information in this document was complete and accurate at the time of printing. However, this information is subject to change. This document will be reissued periodically to incorporate changes.

Cordless Telephone User Guide  
Prepared by the  
Technical Publications Group

---

# Contents

---

<b>1</b>	<b>Introduction</b>	
	Cordless Telephone Controls	2
	Lights	4
	Ringing Tones	4
	Handset Tones	5
<hr/>		
<b>7</b>	<b>System 25 Features</b>	
	Programming System 25 Features	10
	Considerations	10
	Procedures for Programming Features	11

---

# Introduction

This guide lists all of the features available to you from AT&T System 25 through the cordless telephone and provides basic instructions on how to use your cordless telephone to program those features. For a full description of these features, and step-by-step instructions on how to implement them, see the *AT&T System 25 Multiline Telephone User Guide*.

Your cordless telephone is ready to use as soon as it is connected to the System 25. You can still make and receive calls while you are learning to use the System 25 features.

**NOTE:** To ensure optimal operation of your cordless phone, you should make certain that the environmental guides specified for this set have been met.

# Cordless Telephone Controls

The following figures show the controls on the handset and base unit of the cordless telephone. See the owner's manual that accompanied your set for more detailed information on how to use these controls.

## Base Unit Controls

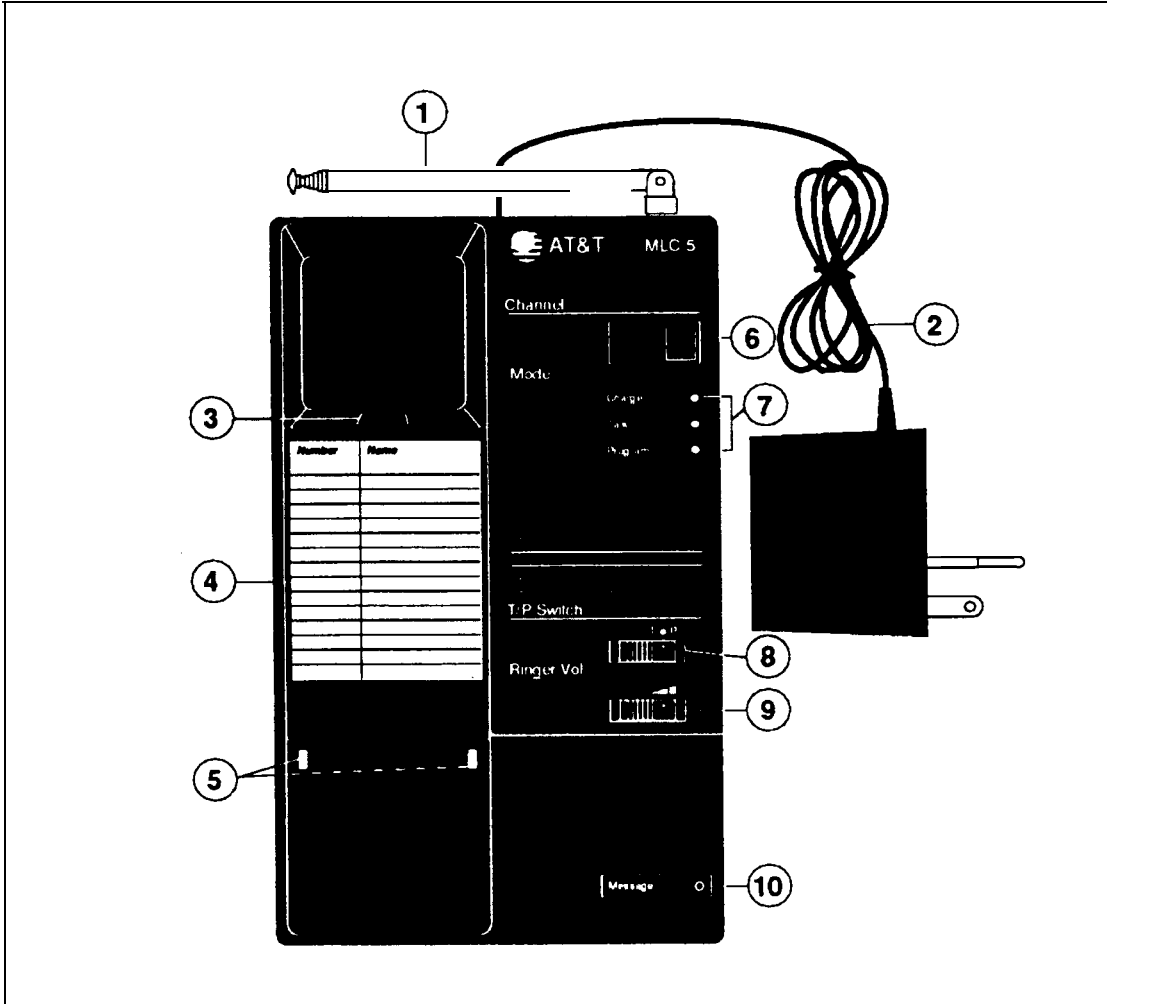

- 1 Retractable Antenna
- 2 Power Cord with AC Adapter
- 3 Handset Hook
- 4 Directory Card
- 5 Battery Contacts

- 6 Channel Indicator
- 7 Mode
- 8 T/P Switch
- 9 Ringer Volume
- 10 Message Light

## Handset Controls

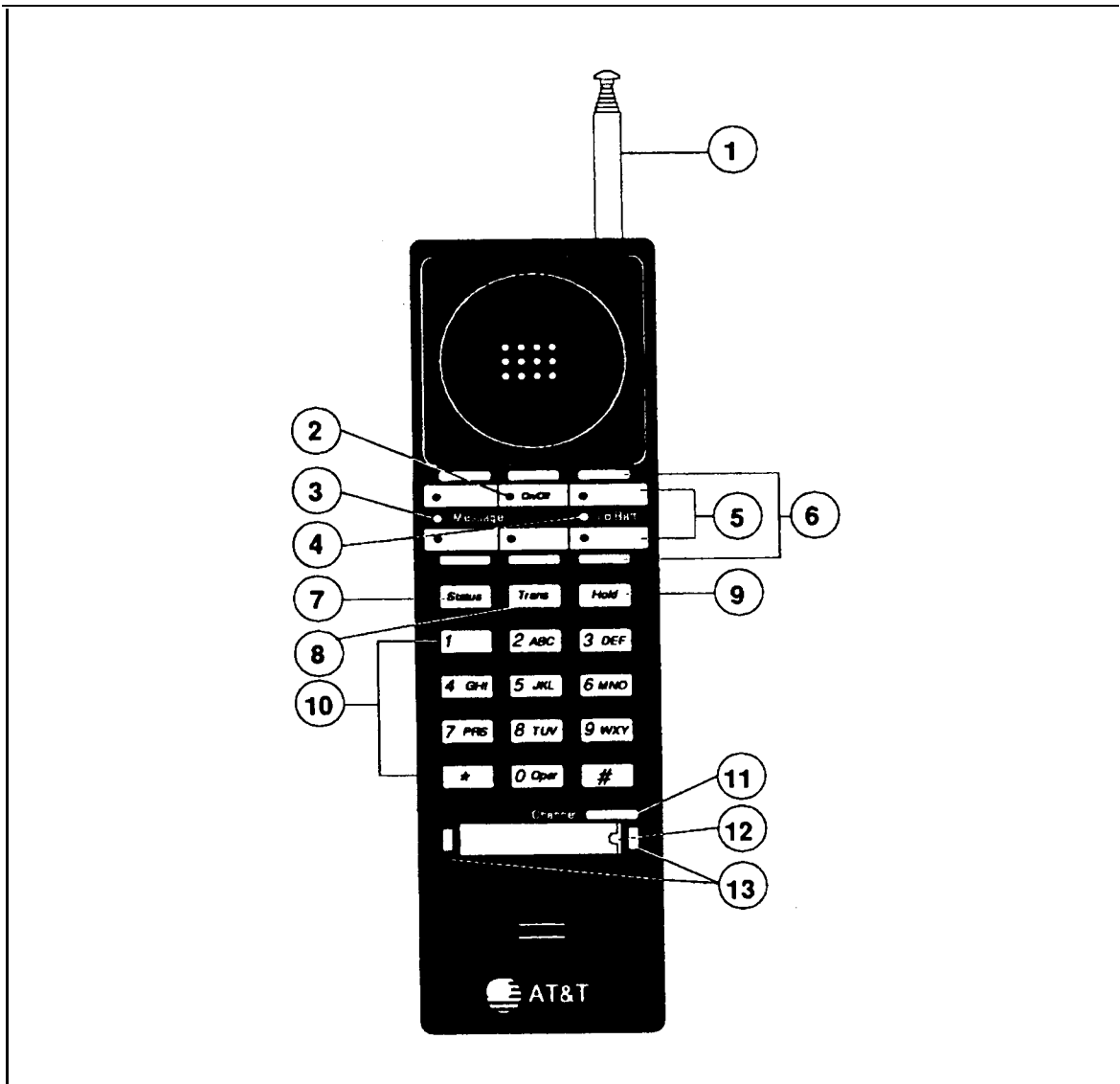

- |                        |                     |
|------------------------|---------------------|
| 1 Antennas             | 8 Transfer          |
| 2 On/Off               | 9 Hold              |
| 3 Message Light        | 10 Dial Pad         |
| 4 Low Battery Light    | 11 Channel          |
| 5 Line Card Label      | 12 Number Card      |
| 6 Line/Feature Buttons | 13 Battery Contacts |
| 7 Status               |                     |







## **Data Dial Code (DDC)**

When your System 25 was installed, Data Dial Codes (DDCs) were assigned to data terminals. If you have a data terminal associated with your System 25, you will receive separate information regarding its use.

## **Personal Dial Code (PDC)**

Personal Dial Codes (PDCs) were assigned to telephones. In most cases, your PDC is your extension number. If a telephone is shared by two or more people, each person may have been assigned his or her own “floating” extension number (FPDC).

## **Additional Information**

See your System Administrator if you have any questions or would like additional information about your System 25 features.

---

## System 25 Features

The cordless telephone implements nearly all the features normally available on a multiline telephone. (Since the cordless telephone does not have a speakerphone, display, or certain function buttons, some features are unavailable.) See the *AT&T System 25 Multiline User Guide* for a full description of features, and detailed procedures on how to implement them.

Your AT&T System 25 has two types of features: fixed and assignable. A fixed feature is one that is provided on all multiline telephones. An assignable feature is *not* provided automatically on all phones. It must be “assigned” by your System Administrator. Check with your System Administrator as to which features have been assigned to you.

The tables starting on the following page list all the features that can be implemented on the cordless telephone and indicate whether they are fixed or assignable features. Also, due to minor design differences between the cordless telephone and other multiline telephones, there are small operational differences regarding the use of certain features on the cordless telephone. Please note the comments for each feature where given.

**NOTE:** Check the tables carefully, as not all multiline features are accessible on your cordless phone.

<b>SYSTEM 25 CORDLESS TELEPHONE FEATURES</b>			
<b>Feature</b>	<b>Fixed</b>	<b>Assignable</b>	<b>Comments</b>
Account Code Entry	✓		
Automatic Intercom		✓	Press ON/OFF, then press status to see current LED states
Bridged Access		✓	Press STATUS to see current LED states
Call Accountability	✓		
Call Waiting		✓	
Callback		✓	
Coverage		✓	Press STATUS to see current LED states
Data Calls		✓	
Direct Group Calling		✓	
Direct Station Selection		✓	
Exclusion		✓	
Following	✓		
Forwarding	✓		
Hold	✓		
Last Number Dialed		✓	Press ON/OFF first
Leave Word Calling		✓	
Message Waiting	✓		

**(Continued)**

<b>SYSTEM 25 CORDLESS TELEPHONE FEATURES</b>			
<b>Feature</b>	<b>Fixed</b>	<b>Assignable</b>	<b>Comments</b>
Night Service		✓	
Paging		✓	
Park	✓		
Personal Message Waiting		✓	
Pickup	✓		
Placing Calls	✓		
Programming Numbers		✓	Press ON/OFF first to use Personal Speed Dial
Repertory Dialing		✓	
Send All Calls		✓	Select Single Ring Reminder
Signaling		✓	
Speed Dialing		✓	
Testing Your Telephone	✓		T/P Switch is located on base unit
Transfer	✓		

## Programming System 25 Features

Although the cordless telephone has five (5) programmable buttons, it must be administered as a 10-button multiline telephone (set 303). This is because the cordless telephone supports the message waiting feature, but the 5-button telephone does not.

### Considerations

- Since the cordless telephone does not have a speakerphone or display, and cannot be used as an attendant console, features that depend on those requirements are not available on the cordless phone.
- If Send All Calls is programmed, select Single Ring Reminder, because there is no *visual* indication when this feature is activated.
- The five programmable buttons on the cordless telephone correspond to buttons 7 through 11 on a regular 10-button telephone, as shown below.

### Order of Appearance of Buttons

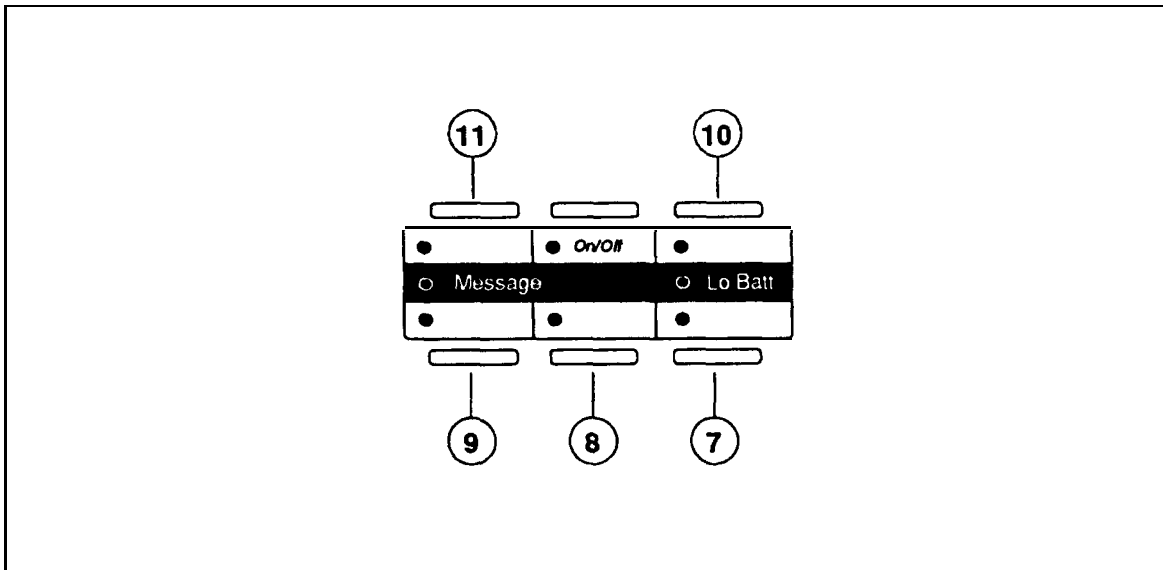

## Procedures for Programming Features

You can program FLEX DSS and Personal Speed Dialing Codes on your cordless telephone. Before you begin this procedure, your cordless phone should have been administered as set 303 by the System Administrator.

- 1 Lift the cordless handset from the base unit. (Make sure **On/Off** is switched to **Off**.)  
*The LED will not be lit.*
- 2 Use a ballpoint pen—not a pencil—to write the names of the features you have selected to program on the corresponding button labels.
- 3 To enter programming mode, slide the T/P switch (located on the base unit) to P.  
*The Channel indicator will display a “ P ” to indicate programming mode.*

**or**

Press **[#] [4]** .

- 4 Press **On/Off**.  
*The light will flash.*
- 5 Keeping the handset close to the base unit, enter the code for the feature you are programming. \*
- 6 Listen for confirmation tone and dial tone.
- 7 Press **On/Off**.  
*The light goes off.*
- 8 If you used the T/P switch to enter programming mode, leave programming mode by sliding the switch back to the center position.

---

\* See the *AT&T System 25 Multiline Telephone User Guide* for detailed procedures on how to implement each feature.